

Product Features

- One - key setting: Sensitivity can be set and the displayed value can be reset with just one key.
- Flexible selection of multiple application modes.
- Ultra - high response time.



PRODUCT TYPE

Article number	Control output	External input	Output	Switching mode	Connection	Wiring	Dimensions
OC10-CNLX	1 output	— —	NPN	L.O / D.O	2 m cable	WD1	see Fig. 1
OC10-CPLX	1 output	— —	PNP	L.O / D.O	2 m cable	WD1	see Fig. 1
OC10-IC2NLX	2 output	1 input	NPN	L.O / D.O	2 m cable	WD3	see Fig. 1
OC10-IC2PLX	2 output	1 input	PNP	L.O / D.O	2 m cable	WD3	see Fig. 1
OC10-ICNLQ8	1 output	1 input	NPN	L.O / D.O	M8 connector	WD2	see Fig. 2
OC10-ICPLQ8	1 output	1 input	PNP	L.O / D.O	M8 connector	WD2	see Fig. 2
OC10-C2NLQ8	2 output	— —	NPN	L.O / D.O	M8 connector	WD4	see Fig. 2
OC10-C2PLQ8	2 output	— —	PNP	L.O / D.O	M8 connector	WD4	see Fig. 2

Wiring Diagrams

WD1 OC10-CNLX/OC10-CPLX

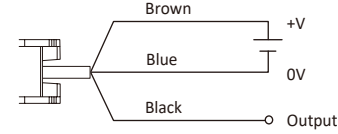

WD2 OC10-ICNLQ8/OC10-ICPLQ8

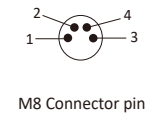
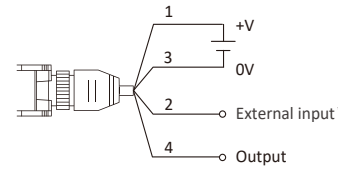

Number	Cable color	Function
1	Brown	+V
2	White	External input
3	Blue	0 V
4	Black	Output

WD3 OC10-IC2NLX/OC10-IC2PLX

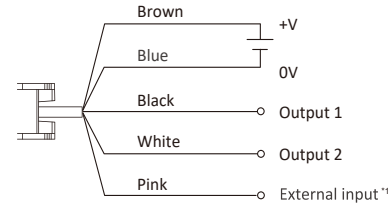

WD4 OC10-C2NLQ8 / OC10-C2PLQ8

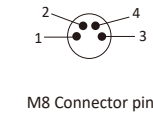
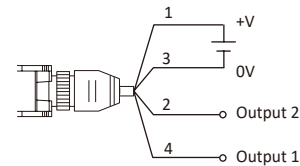

Number	Cable color	Function
1	Brown	+V
2	White	Output 2
3	Blue	0 V
4	Black	Output 1

\*1 Devices with input resistance greater than or equal to 10 kΩ

Technical Parameters

Type		1 - channel output type	
I/O Configuration		Cable	M8 Connector*1
Model	NPN	OC10-CNLX	OC10-ICNLQ8
	PNP	OC10-CPLX	OC10-ICPLQ8
I/O Quantity	Control Output	1-channel Output	1-channel Output
	External Input	---	1-channel Input
Light Source		Red 4 - element Light - Emitting Diode, 660nm	
Response Time		23us(S-HSP) / 50us(HIGH SPEED) / 250us(FINE) / 500us(TURBO) / 1ms(SUPER) / 4ms(ULTRA) / 16ms(MEGA)	
Switching Mode Device		Light - on/Dark - on Selectable	
Timer Function		Timer Off/Off Delay/On Delay/Single - shot	
I/O Specification	Control Output (NPN)	Voltage 24 V DC, 1-output maximum ≤ 100 mA	
	Control Output (PNP)	Voltage 24 V DC, 1-output maximum ≤ 100 mA	
	External Input	Input Time: 2ms (ON)/20ms (OFF) or longer; 25ms (ON/OFF) for calibration input, only for switching to external	
Protection Circuit		Output Short - circuit Protection, Output Reverse Connection Protection, Power Surge Protection, Power Reverse Connection Protection	
Rating Power	Supply Voltage	10...30 V DC ± 10%, Ripple Voltage (P - P): Maximum 10%	
	Consumption (NPN Output Type, Standard Mode)	Normal: 400mW, (Maximum 30mA at 24 V DC, Maximum 36mA at 12 V DC)	
	Consumption (PNP Output Type, Standard Mode)	Normal:400mW, (Maximum 30mA at 24 V DC, Maximum 36mA at 12 V DC)	
Environmental Resistance	Operating Illumination	Incandescent Lamp: 20,000 lux or less, Sunlight: 30,000 lux or less	
	Operating Temperature	-20°C ... +55°C <sup>*2</sup>	
	Storage Temperature	-40°C ... +70°C	
	Vibration Resistance	10 ... 55Hz, Composite Amplitude 1.5mm, 2 hours each in X, Y, Z axes	
	Shock Resistance	500m/s <sup>2</sup> , 3 times each in X, Y, Z axes	
Housing Material		Polycarbonate	
Weight		Approximately 72g	

\*1 For M8 connector types, the cable length must be 30m or less.

\*2 All temperature specifications apply when the module is installed on a DIN rail and a metal frame.

Technical Parameters

Type		2 - channel output type	
I/O Configuration		Cable	M8 Connector*1
Model	NPN	OC10-IC2NLX	OC10-C2NLQ8
	PNP	OC10-IC2PLX	OC10-C2PLQ8
I/O Quantity	Control Output	2-channel Output	2-channel Output
	External Input	1-channel Input	---
Light Source		Red 4 - element Light - Emitting Diode, 660nm	
Response Time		23us(S-HSP) / 50us(HIGH SPEED) / 250us(FINE) / 500us(TURBO) / 1ms(SUPER) / 4ms(ULTRA) / 16ms(MEGA)	
Switching Mode Device		Light - on/Dark - on Selectable	
Timer Function		Timer Off/Off Delay/On Delay/Single - shot	
I/O Specification	Control Output (NPN)	Voltage 24 V DC, 1-output maximum ≤ 100 mA, 2-output total ≤ 100 mA	
	Control Output (PNP)	Voltage 24 V DC, 1-output maximum ≤ 100 mA, 2-output total ≤ 100 mA	
	External Input	Input Time: 2ms (ON)/20ms (OFF) or longer; 25ms (ON/OFF) for calibration input, only for switching to external	
Protection Circuit		Output Short - circuit Protection, Output Reverse Connection Protection, Power Surge Protection, Power Reverse Connection Protection	
Rating Power	Supply Voltage	10...30 V DC ± 10%, Ripple Voltage (P - P): Maximum 10%	
	Consumption (NPN Output Type, Standard Mode)	Normal: 400mW, (Maximum 30mA at 24 V DC, Maximum 36mA at 12 V DC)	
	Consumption (PNP Output Type, Standard Mode)	Normal:400mW, (Maximum 30mA at 24 V DC, Maximum 36mA at 12 V DC)	
Environmental Resistance	Operating Illumination	Incandescent Lamp: 20,000 lux or less, Sunlight: 30,000 lux or less	
	Operating Temperature	-20°C ... +55°C <sup>*2</sup>	
	Storage Temperature	-40°C ... +70°C	
	Vibration Resistance	10 ... 55Hz, Composite Amplitude 1.5mm, 2 hours each in X, Y, Z axes	
	Shock Resistance	500m/s <sup>2</sup> , 3 times each in X, Y, Z axes	
Housing Material		Polycarbonate	
Weight		Approximately 72g	

\*1 For M8 connector types, the cable length must be 30m or less.

\*2 All temperature specifications apply when the module is installed on a DIN rail and a metal frame.

Dimensions

**Fig. 1** OC10-CNLX/OC10-CPLX OC10-IC2NLX/OC10-IC2PLX

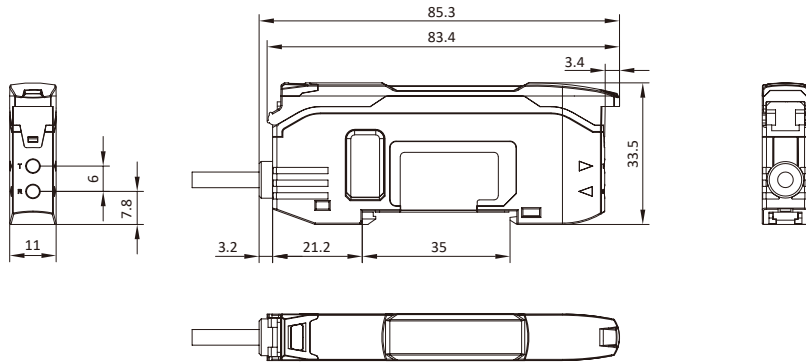

**Fig. 2** OC10-ICNLQ8/OC10-ICPLQ8 OC10-C2NLQ8/OC10-C2PLQ8

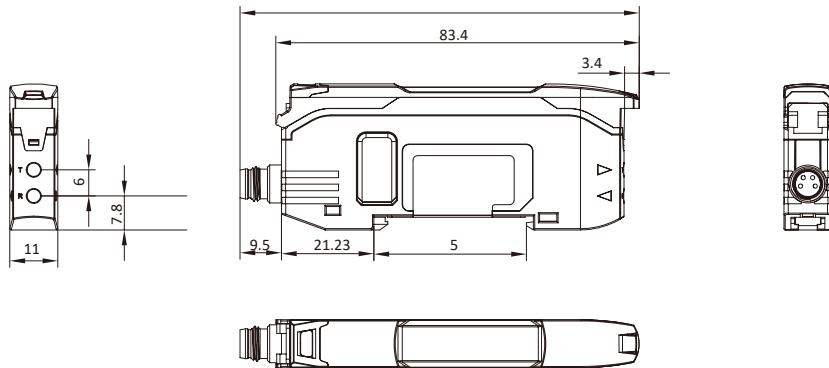

Operation Indicator

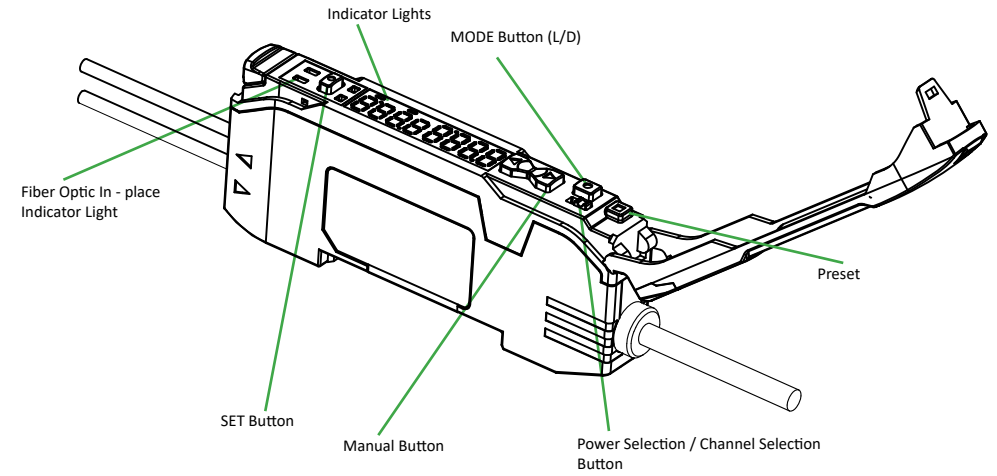

Basic Operation:

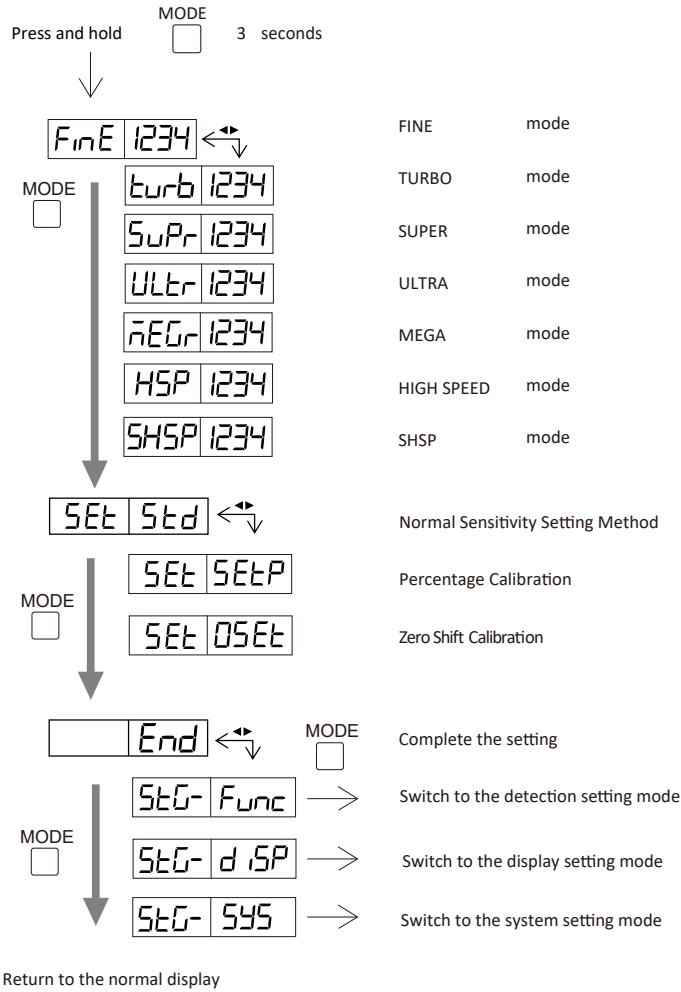

Detection Settings:

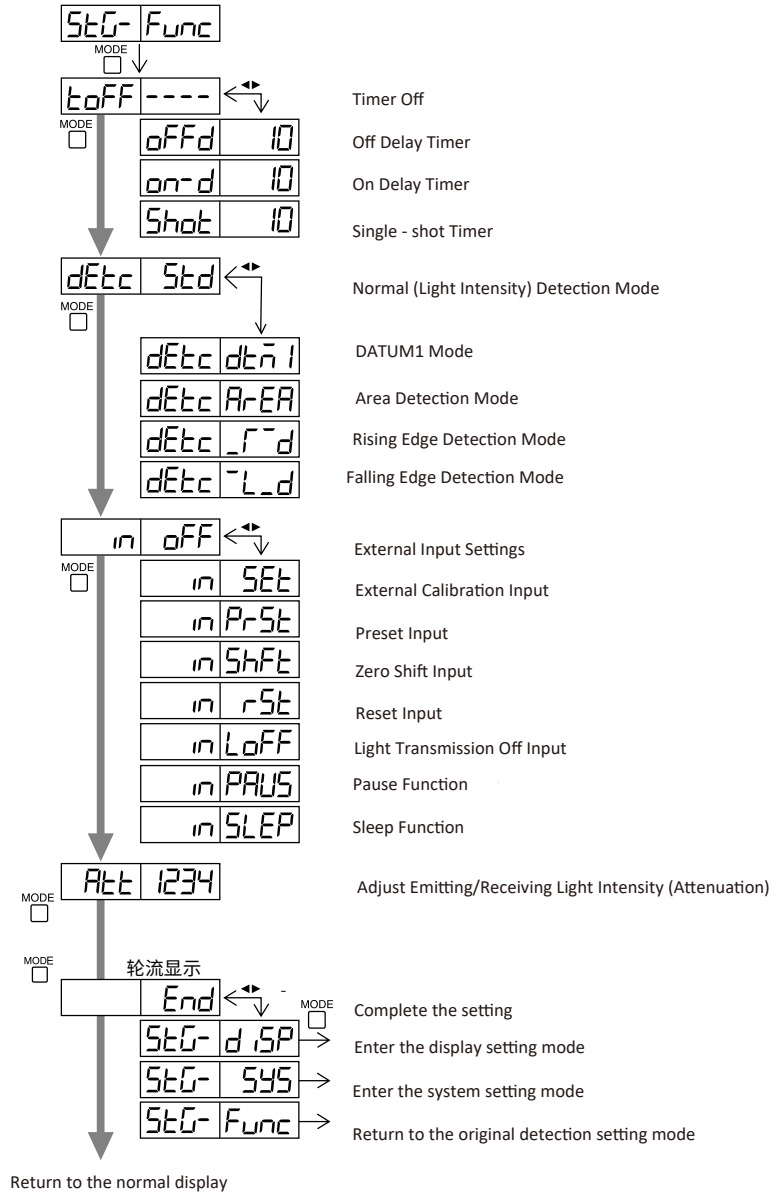

Display Settings:

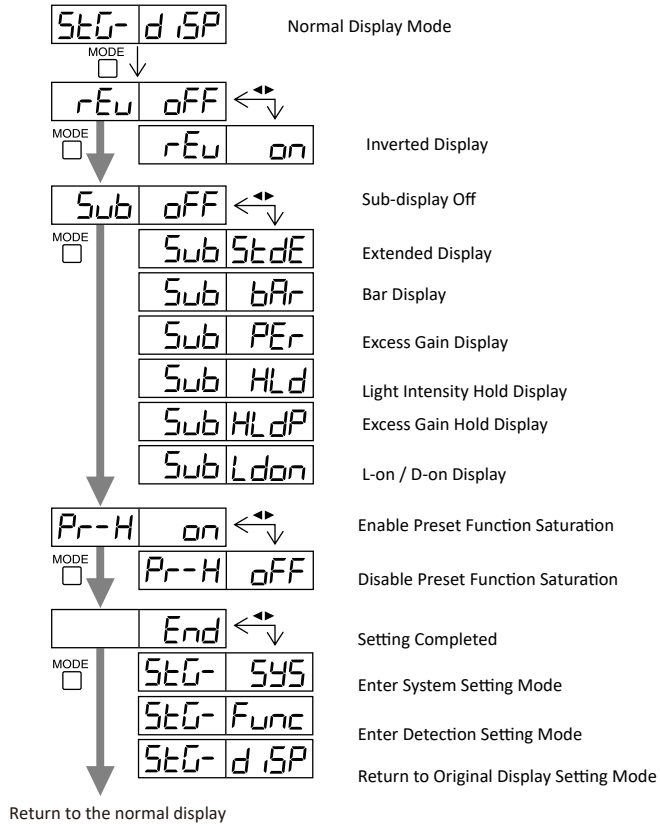

System Settings:

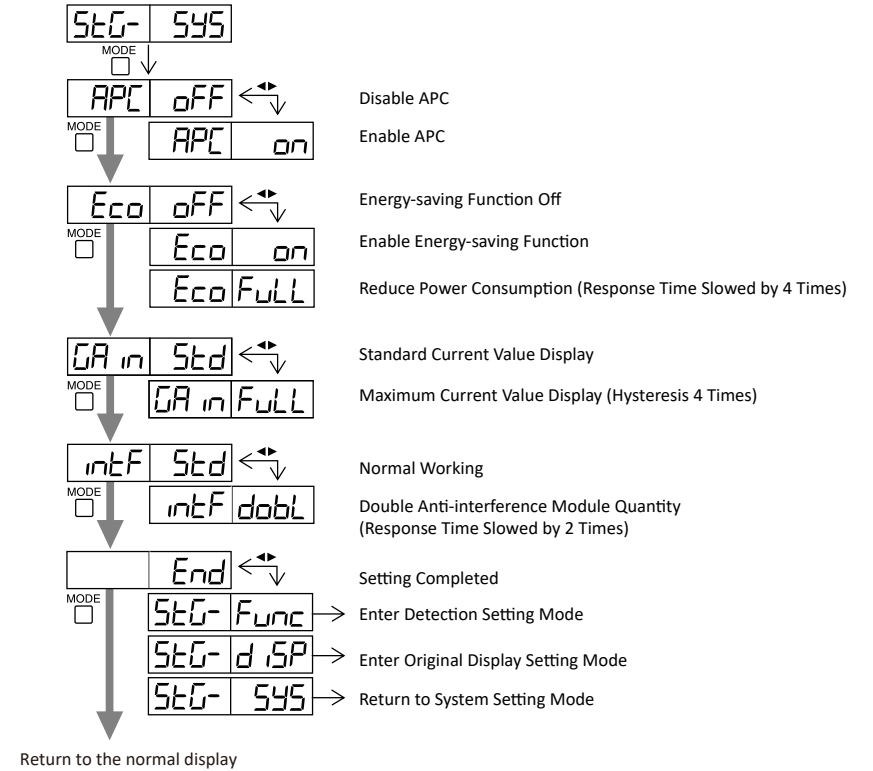

2nd Output:

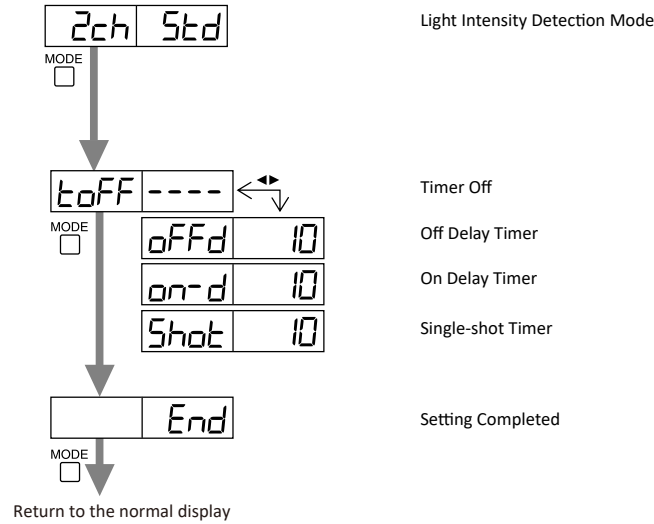

Saturation Cancellation Function

Enable Saturation Cancellation Function: Press and hold the [MODE] button while pressing the [SET] button.  
 The setting range for the received light intensity corresponding to the power mode is set within the range shown in the following table.

Power Mode	Setting Range of Received Light Intensity
HSP 、 FINE 、 TURBO	2047±350
SUPER	4095±500
ULTRA 、 MEGA	5000±600

Disable Saturation Cancellation Function: Press and hold the [MODE] button while pressing the [SET] button.

Three Timer Functions

There are three available timer types.

Display	Function	Timing chart*
toFF	Uses no output timer. (Default)	
offd	Off-delay timer Turns off the output at a specified time after the detection signal goes off. Setting range: 1 to 9999 ms Default: 10 ms	
on-d	On-delay timer Turns on the output at a specified time after the detection signal goes on. Useful if the ON duration is limited because the workpiece is shaky such as by vibration. Setting range: 1 to 9999 ms Default: 10 ms	
Shot	One-shot timer Turns on the output and keeps it on for a specified period after the detection signal goes on. Setting range: 1 to 9999 ms Default: 10 ms	

## Output 2 - Output Timer

There are three available timer types.

Display	Function	Timing chart *
toFF	Uses no output timer. (Default)	
oFFd	Off-delay timer Turns off the output at a specified time after the detection signal goes off. Setting range: 1 to 9999 ms Default: 10 ms	
on-d	On-delay timer Turns on the output at a specified time after the detection signal goes on. Useful if the ON duration is limited because the workpiece is shaky such as by vibration. Setting range: 1 to 9999 ms Default: 10 ms	
Shot	One-shot timer Turns on the output and keeps it on for a specified period after the detection signal goes on. Setting range: 1 to 9999 ms Default: 10 ms	

## Output Switching (L-on/D-on)

This function configures when the output turns ON

1 Press the [MODE] button while the currently received light intensity is displayed.

The current output condition (L-on or D-on) is displayed.



2 Press the [ ] button to switch the output condition, then press the [MODE] button.

For Through-beam or Retro-reflective types, select "D-on" if you want an ON signal to be output when the beam is blocked (workpiece present).

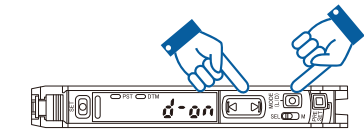

For Diffuse-reflective types, select "L-on" if you want an ON signal to be output when the beam is received (workpiece present).

The currently received light intensity is displayed when

### 1. Preset Function

Enable Preset Function:

When no workpiece is present, simply press the [PRESET] button to complete sensitivity adjustment.

Upon pressing the PRESET button, the software records the maximum light intensity value within 3 seconds and sets this maximum value as the 100% reference. Simultaneously, the set value is configured to 50%, and the PST indicator lights up.

Disable Preset Function::

While the PST indicator is lit, press and hold the [PRESET] button

The preset function is disabled when the PST indicator turns off.

### 2. Work Preset Function

This function calibrates the current value to "0". After performing the preset function with the parameter "100.0", executing this function with the parameter ".0" allows calibration of two arbitrary setpoints to "100.0" and ".0".

Enable Work Preset Function:

While the preset function is enabled, simultaneously press the [PRESET] and [RIGHT] buttons.

This sets the received light intensity at that point to ".0". The value set by the preset function as "100.0" remains unchanged.

Disable Work Preset Function:

When the PST indicator is lit, press and hold the [PRESET] button

The work preset function is disabled when the PST indicator turns off.

### 3. Maximum Sensitivity Preset

This function calibrates the reference state to "0" and sets the received light intensity state slightly higher, i.e., to "100.0".

This function can be used with the diffuse-reflective type to perform detection when using the background as a reference.

Enable Maximum Sensitivity Preset Function:

When using a diffuse-reflective type device without any workpiece present, or when using a through-beam/retro-reflective type device with a workpiece present, press and hold the [PRESET] button for more than three seconds while the PST indicator is OFF. Release the button when the "Auto" light flashes. Calibration is completed when the PST indicator turns orange and the set value is configured to "50.0".

Disable Maximum Sensitivity Preset Function: When the PST indicator is lit, press and hold the [PRESET] button.

The PST indicator will turn off, indicating that the maximum sensitivity preset function has been disabled.

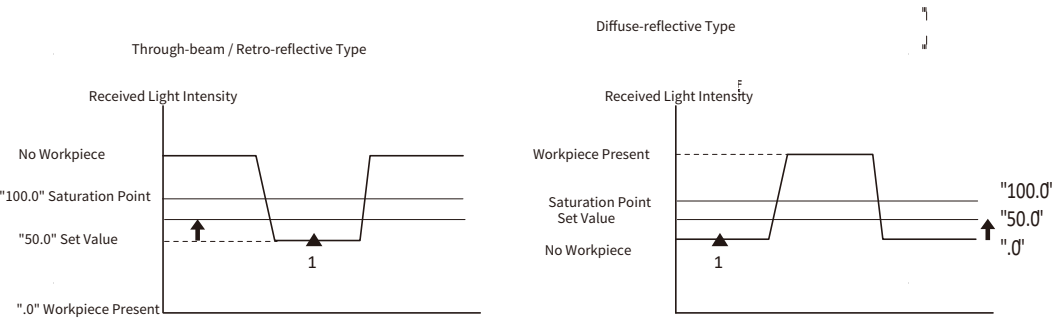

### 4. Two-Point Calibration

Two-point calibration is the most fundamental method for sensitivity setting. Simply press the [SET] button once when the workpiece is present and once when it is absent to establish the set value.

When the workpiece is absent, press the [SET] button once.

When the workpiece is present, press the [SET] button once.

After the set value calibration is complete, press the [LEFT] or [RIGHT] button to fine-tune the set value.

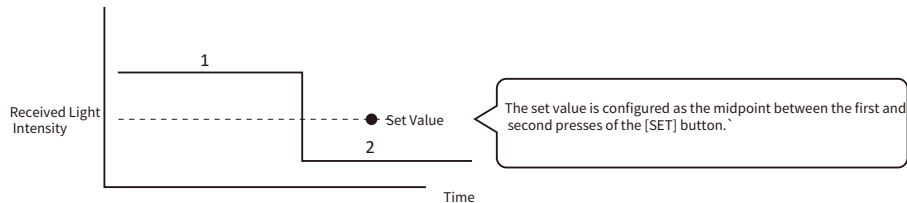

### 5. Maximum Sensitivity Calibration

For diffuse-reflective type devices when no workpiece is present, or for through-beam/retro-reflective type devices when a workpiece is present, press and hold the [SET] button for more than three seconds.

Release the button when the "SET" indicator flashes. Once the set value calibration is complete, press the left/right buttons to adjust the set value.

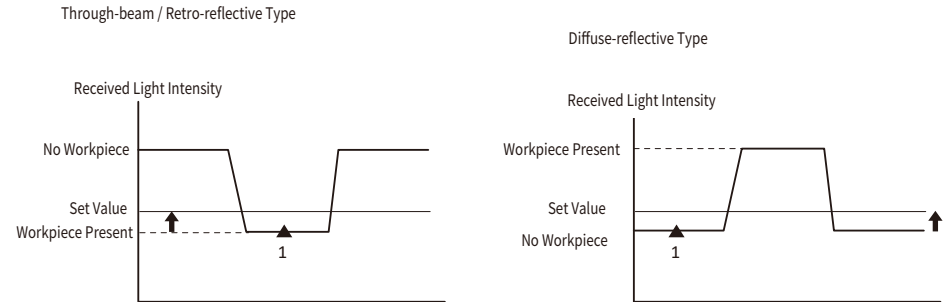

### 6. Full Auto Calibration

This method automatically sets the sensitivity using a moving workpiece. The sensitivity can be easily set while the workpiece passes through, without the need to shut down the operating equipment.

When no workpiece is present, press and hold the [SET] button until "SET" flashes. After the workpiece has completely passed through, release the [SET] button. The set value calibration is now complete.

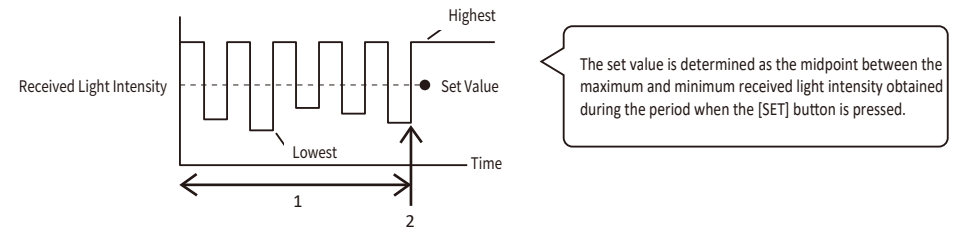

## 7. Positioning Calibration

When no workpiece is present, press the [SET] button once. Position the workpiece so that its edge aligns with the center of the projected beam. Then, press and hold the [SET] button for more than three seconds. Release the button when "SET" flashes. Press the [LEFT] or [RIGHT] button to adjust the set value. When the workpiece reaches the position, the set value is determined based on the received light intensity value.

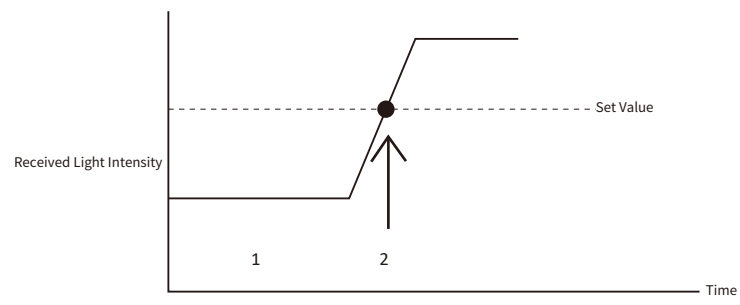

## 8. Zero Shift Function

This function adjusts the display of the currently received light intensity to "0". It is primarily used with diffuse-reflective sensors. When installing a diffuse-reflective device, if the received light intensity cannot be set to "0", this function can be used in the absence of a workpiece to set the received light intensity to "0". This makes it easier to distinguish differences in received light intensity.

**Enable Zero Shift Function:**

When the PST indicator is off, simultaneously press the [PRESET] and [RIGHT] buttons. The PST indicator will turn orange, and the received light intensity will change to "0".

**Disable Zero Shift Function:**

Press and hold the [PRESET] button. The PST indicator will turn off, indicating that the zero shift function has been disabled.

## 9. Load Recommended Settings (Menu Function)

Simultaneously press and hold the [SET] and [PRESET] buttons for three seconds or longer. The "rst" display will blink.

Press the left/right buttons to display "LOAD", then press the [MODE] button.

Press the left/right buttons to select the desired menu setting, then press the [MODE] button. After loading the settings, the screen will display "LOAD OK" and then switch to the currently received light intensity.

## 10. Initialization

The sensor amplifier can be reset to factory default settings.

Simultaneously press and hold the [SET] and [PRESET] buttons for three seconds or longer. The "rst" display will blink.

Press the [MODE] button. Press the [LEFT]/[RIGHT] buttons to display "init". Press the [MODE] button.

After initializing the settings, the screen will display "OK", then switch to the currently received light intensity.

## 11. Key Lock

The key lock function disables all button operations to prevent unauthorized use. Activate Key Lock: Simultaneously press and hold the [MODE] button and [LEFT] (or [RIGHT]) for three seconds or longer. The screen will display "Loc", all button operations will be disabled, and the currently received light intensity will be displayed. Deactivate Key Lock: Simultaneously press and hold the [MODE] button and [LEFT] (or [RIGHT]) for three seconds or longer. The screen will display "unt", and button operations will be enabled.

## 12. Key Lock with PIN Code

A PIN code can be set when activating the key lock function. Only users who know the PIN code can operate the lock.

**Activate Key Lock with PIN Code:**

Press the (left or right button) 10 times while holding down the [MODE] button. The screen will display "Loc 0". Use the left/right buttons to set the desired code (up to four digits). Press the [MODE] button. The screen will display "loc", button operations will be disabled, and the currently received light intensity will be shown.

**Deactivate Key Lock with PIN Code:**

Hold down the [MODE] button while pressing the (left or right button) 10 times. The screen will display "Loc 0". Use the left/right buttons to enter the PIN code. Then press the [MODE] button. The screen will display "unl", and button operations will be enabled.

### 13. Power Mode Setting

On the channel or light screen display interface, hold down the MODE button for three seconds to enter the power setting interface. Press the [LEFT] or [RIGHT] button to select different power modes.

Display	Power Mode Name	Response Time
ShSP	SUPER HIGH SPEED	23 μs
hSP	HIGH SPEED	50 μs
FinE	FINE	250 μs
turb	TURBO	500 μs
SuPr	SUPER	1 ms
ULtr	ULTRA	4 ms
MEGA	MEGA	16 ms

### 14. Sensitivity Setting

#### 14.1 Percentage calibration

Setup value can be configured at the ratio to the current received light intensity. The percentage calibration target value can be set in the range of "1P" (1%) to 199P (199%). Default: 90P (90%).

Press the [SET] button under the desired reference state.

Setting Example: When the percentage calibration target value is set to "90%".

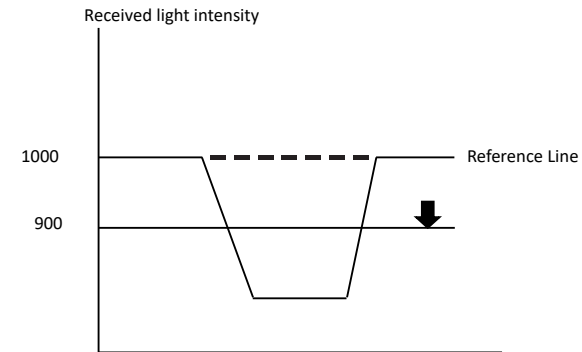

#### 14.2 Zero shift calibration

This sensitivity setting performs the zero shift function and basic calibration (two-point calibration / maximum sensitivity calibration / full auto calibration) simultaneously. The lower of the received light intensity values specified at the time of sensitivity setting will automatically be set to "0".

Setting Example: If two-point calibration is performed with a reflective model when the light intensity received with a workpiece is "2500" and without a workpiece is "500":

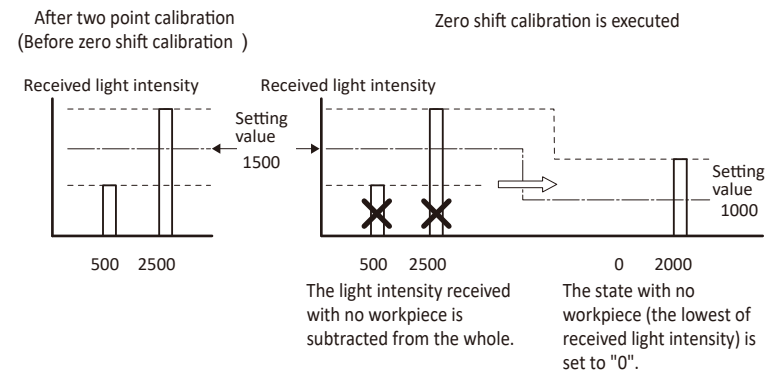

### 15. Detection Mode

#### 15.1 DATUM1 mode

In DATUM1 mode, the light intensity received without a workpiece is always corrected to "100.0". The setting value is also corrected according to the correction amount, so that the ratio of setting value and received light intensity is kept constant, with the result of stable detection. The display of the setting value does not change.

The DATUM mode is effective in environments where received light intensity varies gradually, for example where the sensor head is prone to contamination or large temperature changes.

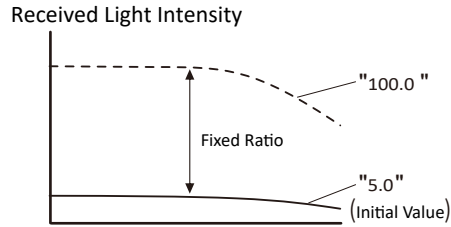

#### Changing the Warning Output Level

**Display Example** When the warning output level is set to 50%, dtm1, D-on:

The unit goes into alarm mode when it detects a minor level of variation of received light intensity that does not cause the output to turn ON. If the received light intensity continues to remain between the warning level and setup level, the received light intensity correction function stops, the DTM indicator flashes, and the unit goes into alarm mode.

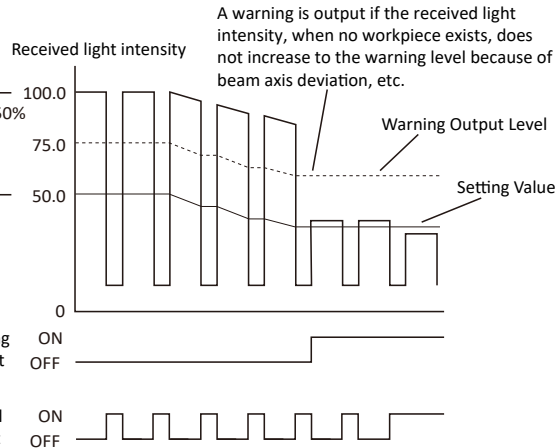

A level for outputting a warning can be set in the range of 0P (0%) to 100P (100%). (Default: 50P (50%).)

- 100P (100%) The unit does not go into alarm mode if the received light intensity varies.
- 50P (50%) If no workpiece is detected, the unit goes into alarm mode when the received light intensity lowers to the intermediate value between the received light intensity and the set value.
- 0P (0%) The unit goes into alarm mode when the level of received light intensity lowers even slightly.

A desired correction interval can be selected from the 3 levels:

POWER MODE	LEv1 (LEVEL1)	LEv2 (LEVEL2)	LEv3 (LEVEL3)
HIGH SPEED	4.4 s	547.2 ms	34.2 ms
FINE	13.1 s	1.64 s	102.4 ms
TURBO/SUPER/ULTRA/MEGA	26.2 s	3.27 s	204.8 ms

#### 15.2 Area detection mode

In this mode, the output signal is delivered (in N.O. condition) if the received light intensity is in the area defined by Hi (upper limit) and Lo (lower limit).

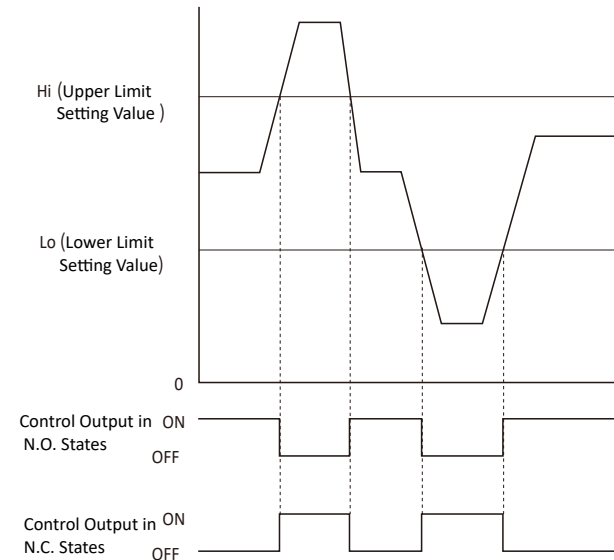

Press [LEFT] or [RIGHT] to display "Hi" or "Lo". The "Hi" or "Lo" value, and the current setting values are displayed alternately.

When the [MODE] button is pressed while the display alternately flashes, the "Hi" or "Lo" display changes. If you do nothing for 3 seconds or more, the received light intensity display is automatically restored.

Use [LEFT]/[RIGHT] to modify the Hi/Lo values, ensuring that Hi > Lo at all times.

#### 15.3 Edge Detection Mode

In the edge detection mode, the sensor amplifier detects changes of received light intensity over a fixed period. This mode is used to turn on the output only when a workpiece is moving into or out of the detection range of the fiber unit.

Turning the output ON when the received light intensity attenuates.

---->Select Falling edge detect mode

To turn the output ON when the received light intensity increases:

----> Select Rising edge detect mode

## 16. External Inputs

16.1 Set: External calibration input. Uses an external input to perform calibration operations.

16.2 PrSt: Preset input. Uses an external input to perform preset operations.

16.3 ShFt: Zero shift input. Uses an external input to perform zero shift operations.

16.4 rSt: Reset input. Uses an external input to perform reset operations.

16.5 LoFr: Transmission OFF input. Keeps the transmission turned off during the signal input period.

16.6 PAUS: Pause function. Locks the output condition during the external input. During the signal input, the output can be locked to the desired state regardless of the received light input.

16.7 SLEP: Sleep function. Enables power saving mode during the external input.

## 17. Adjusting Emitted/Received Light Intensity (Func-Att)

When a high-performance (longer detection range) fiber sensor unit is used within a short range, the received light intensity may remain saturated at the maximum value within the enabled display range, regardless of the presence or absence of a workpiece. (Example: The value remains constant at the maximum of 9999). In such cases, the attenuation function can be used to manually and automatically correct the emitted and received light intensity to the optimal state. Use the left/right arrow keys to decrease the lower limit value; the received light intensity will be attenuated more. Setting range: 1 to 100 (Initial value: 100).

## 18. Display Inversion (DISP+REU) (DiSP-rEu)

The current value and set value are displayed inverted.

Display	Function
oFF (OFF)	Normal display (default setting)
on (ON)	Inverted display

## 19. Expanded Display (DiSP-Sub-StdE)

The normally displayed 4-digit received light intensity is expanded to a 5-digit display. The upper limit of the set value remains 4 digits (9999). Larger values cannot be set.

## 20. Graph Display (DiSP-Sub-bAr)

The received light intensity can be displayed as a bar graph. The bars are displayed in real-time, ranging from 85% to 115% in 5% increments, where 100% represents the set value. A maximum of eight bars can be displayed.

## 21. Excess Gain (%) Display (DiSP-Sub-PEr)

The received light intensity is displayed as an excess gain relative to the set value. On the screen, the received light intensity is shown as both a bar graph and a percentage number. Excess Gain = (Received Light Intensity / Set Value) × 100.

## 22. Light Intensity Hold Display (DISP-Sub-HLd)

The maximum peak and minimum valley values of the received light intensity can be continuously displayed. You can choose from five possible display combinations.

Display	Values Displayed
Std (Standard)	The current received light intensity value, updated in real-time when it falls below or exceeds the set value. (Default setting)
P~P_ (Peak Max/Peak Min)	e maximum and minimum peak values recorded since power-on. (Cumulative)
b~b_ (Bottom Max/Bottom Min)	The maximum and minimum valley values recorded since power-on. (Cumulative)
P_b~ (Peak Min/Bottom Max)	The minimum peak value and maximum valley value recorded since power-on. (Cumulative).
P~b_ (Peak Max/Bottom Min)	The maximum peak value and minimum valley value recorded since power-on. (Cumulative)

## 23. Excess Gain Hold (%) Display (DiSP-Sub-HLdP)

This function is the same as the "Received Light Intensity Hold Display", except the saved values are displayed as excess gain instead of received light intensity.

### 24. Preset Saturation Function (DISP-Pr-H)

When the preset saturation function is set to ON, the saturation level can be set within the range of 100P (100%) to 200P (200%). For example, if this function is set to 150P, when the preset function is enabled, the received light intensity will be calibrated to "150.0", and the digital display will show "100.0". Advanced Function Setting.

The saturation level can be set to a higher value to achieve stable detection even in environments prone to contamination (e.g., dust). If you need to display values higher than "100.0" in applications using the preset function or DATUM1 mode, turn this function OFF.

Display	Function
on (ON)	When the actual received light intensity is higher than 100.0, the display will be fixed at "100.0" (values above "100.0" are not displayed). (Default: 110P)
oFF (OFF)	Displays the actual received light intensity as is, even if it is higher than "100.0".

The preset input is used to record the light intensity as "100.0".

The actual received light intensity (3300) is set to "110%", so that all light intensity values exceeding "100%" are displayed as "100.0".

When the light intensity falls below "100%", a value lower than "100.0" is displayed.

(The percentage value "110%" recorded at the time (i.e., the saturation level) can be any value between 100% and 200%.)

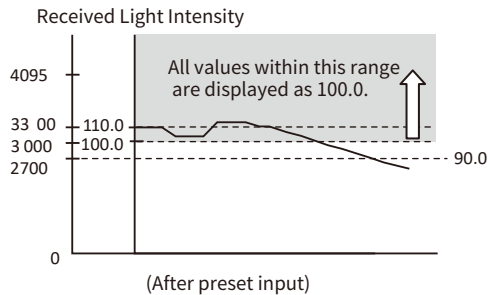

### 25. APC Function(SYS-APC)

The APC (Automatic Power Control) function automatically adjusts the emitted light to maintain a constant level. This function reduces variations in the received light intensity caused by changes in ambient temperature.

Screen Display	Function
oFF (OFF)	APC function disabled (Initial setting)
on (ON)	APC function enabled

### 26. Eco Function (SYS-Eco)

Power consumption can be reduced by turning off the digital display and output indicators.

26.1 on(ON): Enables the Eco function. (A segment on the digital display blinks.)

26.2 FuLL(FULL) : Reduces power consumption (Eco function is active, and response time is increased fourfold).

### 27. Display Gain (SYS-GRin) (SYS-GRin)

The received light intensity can be amplified fourfold without sacrificing response time.

Display	Function
Std ( Standard )	Normal light intensity display (Default setting)
FuLL ( Full )	Full light intensity display (Hysteresis is quadrupled)

### 28. Custom Save (Save Settings)

Simultaneously press and hold the [SET] and [PRESET] buttons for three seconds or longer.

The "rst" display will blink.

Press the left/right arrow buttons to display "SAVE", then press the [MODE] button.

Press the left/right arrow buttons to display "YES", then press the [MODE] button.

After the settings are saved, the screen displays "OK" and then switches to the currently received light intensity.

### 29. User Reset (Recall Settings)

Settings saved using the Custom Save function can be recalled. If a User Reset is performed, the settings saved via the Custom Save function will overwrite all previous settings.

1. Simultaneously press and hold the [SET] and [PRESET] buttons for three seconds or longer.

The "rst" display will blink.

2. Press the [MODE] button.

3. Press the left/right arrow buttons to display "USEF", then press the [MODE] button. After the User Reset is executed, the screen displays "OK" and then switches to the currently received light intensity.

### Installation method

Installation method for mounting fiber amplifier to DIN rail

1. Align the gripper at the bottom of the product with the DIN track. While pushing the product in the direction of arrow 1, tilt it towards arrow 2.

The disassembly method of the fiber optic amplifier on the DIN rail

2. The way to remove the sensor is to lift the product in the direction of arrow 3 while pushing the product in the direction of arrow 1.

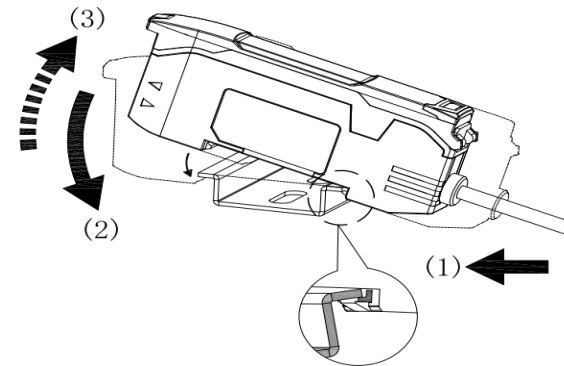

### Install it on the wall

Install the sensor together with the optional EOC10-1 and secure it with screws as shown in the illustration.

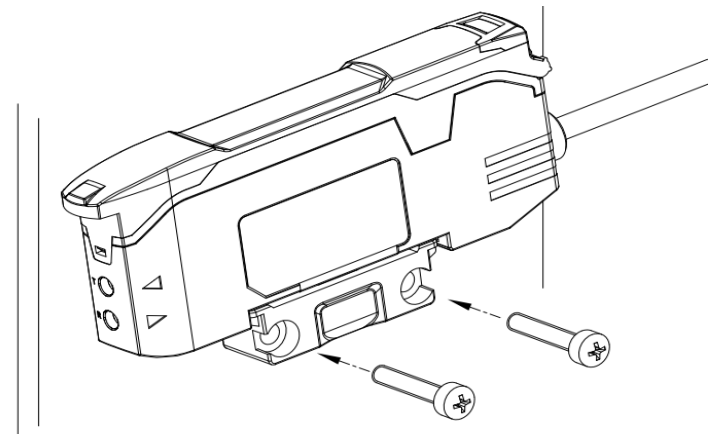

产品特点:

- 一键设定:只需一键即可设置灵敏度并置显示值
- 多种应用模式灵活选择
- 超高响应时间



产品型号

型号	控制输出	外部输入	输出	开关类型	连接方式	接线图	尺寸图
OC10-CNLX	1路输出	--	NPN	亮通/暗通	2 m 线缆	WD1	图 1
OC10-CPLX	1路输出	--	PNP	亮通/暗通	2 m 线缆	WD1	图 1
OC10-IC2NLX	2路输出	1路输入	NPN	亮通/暗通	2 m 线缆	WD3	图 1
OC10-IC2PLX	2路输出	1路输入	PNP	亮通/暗通	2 m 线缆	WD3	图 1
OC10-ICNLQ8	1路输出	1路输入	NPN	亮通/暗通	M8 连接器	WD2	图 2
OC10-ICPLQ8	1路输出	1路输入	PNP	亮通/暗通	M8 连接器	WD2	图 2
OC10-C2NLQ8	2路输出	--	NPN	亮通/暗通	M8 连接器	WD4	图 2
OC10-C2PLQ8	2路输出	--	PNP	亮通/暗通	M8 连接器	WD4	图 2

接线图

WD1 OC10-CNLX/OC10-CPLX

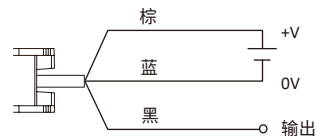

WD2 OC10-ICNLQ8/OC10-ICPLQ8

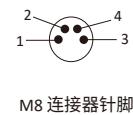
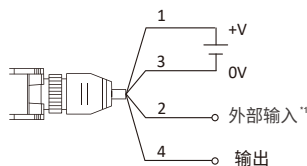

引脚	线色	功能
1	棕	+V
2	白	外部输入 <sup>*1</sup>
3	蓝	0V
4	黑	输出

WD3 OC10-IC2NLX/OC10-IC2PLX

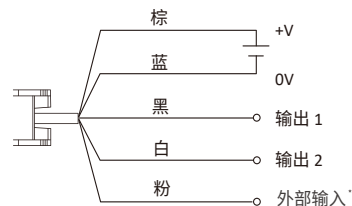

WD4 OC10-C2NLQ8 / OC10-C2PLQ8

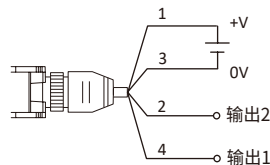

引脚	线色	功能
1	棕	+V
2	白	输出2
3	蓝	0V
4	黑	输出1

\*1 输入电阻大于等于 10 k Ω 的设备

## 技术参数

类型		1 路输出型	
输入 / 输出配置		电缆	M8 连接器 *1
型号	NPN	OC10-CN LX	OC10-ICNLQ8
	PNP	OC10-CPLX	OC10-ICPLQ8
输入 / 输出	控制输出	1路输出	1 路输出
	外部输入		1 路输入
光源		红色4元素发光二极管660nm	
响应时间		23us(S-HSP) / 50us(HIGH SPEED) / 250us(FINE) / 500us(TURBO) / 1ms(SUPER) / 4ms(ULTRA) / 16ms(MEGA)	
开关模式设备		亮暗通可设置	
定时器功能		定时器关闭 / 关闭延迟 / 开启延迟 / 单次	
输入 / 输出规格	控制输出 (NPN)	电压24 V DC, 单路输出最大值: ≤100mA	
	控制输出 (PNP)	电压24 V DC, 单路输出最大值: ≤100mA	
	外部输入	输入时间: 2 ms (ON)/20 ms (OFF) 或更长。25 ms(ON/OFF), 仅限切换到外部校准输入时	
保护电路		输出短路保护,输出逆连接保护,电源浪涌保护,电源逆接保护	
额定值	电源电压	10...30 V DC ± 10% , 波纹电压(P-P): 最大 10%	
	功耗 (NPN 输出类型) (标准模式)	正常400mW, (24 V DC 时最大30mA, 12 V DC 时最大36mA)	
	功耗 (PNP 输出类型) (标准模式)	正常400mW, (24 V DC 时最大30mA, 12 V DC 时最大36mA)	
环境耐受性	工作亮度	白炽灯: ≤ 20000 lux; 日光: ≤ 30000 lux	
	工作温度	-20 °C ... +55°C *2	
	存储温度	-40 °C ... +70°C	
	抗振性	10 ... 55 Hz, 复合振幅1.5 mm, X、Y、Z 轴方向各两小时	
	抗震性	500 m/s <sup>2</sup> , 每个 X、Y、Z 轴各3次	
外壳材料		聚碳酸酯	
质量		约 72 g	

\*1 对于 M8 连接器类型, 电缆长度必须小于 30 m 或更短。

\*2 所有温度规格适用于模块安装到 DIN 导轨上以及安装到金属框架的情形。

## 技术参数

类型		2 路输出型	
输入 / 输出配置		电缆	M8 连接器 *1
型号	NPN	OC10-IC2NLX	OC10M-C2NLQ8
	PNP	OC10-IC2PLX	OC10M-C2PLQ8
输入 / 输出	控制输出	2路输出	2路输出
	外部输入	1路输入	---
光源		红色4元素发光二极管660nm	
响应时间		23us(S-HSP) / 50us(HIGH SPEED) / 250us(FINE) / 500us(TURBO) / 1ms(SUPER) / 4ms(ULTRA) / 16ms(MEGA)	
开关模式设备		亮暗通可设置	
定时器功能		定时器关闭 / 关闭延迟 / 开启延迟 / 单次	
输入 / 输出规格	控制输出 (NPN)	电压24 V DC, 单路输出最大值: ≤100mA; 双路输出总值: ≤100mA	
	控制输出 (PNP)	电压24 V DC, 单路输出最大值: ≤100mA; 双路输出总值: ≤100mA	
	外部输入	输入时间: 2 ms (ON)/20 ms (OFF) 或更长。25 ms(ON/OFF), 仅限切换到外部校准输入时	
保护电路		输出短路保护,输出逆连接保护,电源浪涌保护,电源逆接保护	
额定值	电源电压	10...30 V DC ± 10% , 波纹电压(P-P): 最大 10%	
	功耗 (NPN 输出类型) (标准模式)	正常400mW, (24 V DC 时最大30mA, 12 V DC 时最大36mA)	
	功耗 (PNP 输出类型) (标准模式)	正常400mW, (24 V DC 时最大30mA, 12 V DC 时最大36mA)	
环境耐受性	工作亮度	白炽灯: ≤ 20000 lux; 日光: ≤ 30000 lux	
	工作温度	-20 °C ... +55°C *2	
	存储温度	-40 °C ... +70°C	
	抗振性	10 ... 55 Hz, 复合振幅1.5 mm, X、Y、Z 轴方向各两小时	
	抗震性	500 m/s <sup>2</sup> , 每个 X、Y、Z 轴各3次	
外壳材料		聚碳酸酯	
质量		约 72 g	

\*1 对于 M8 连接器类型, 电缆长度须小于 30 m 或更短。

\*2 所有温度规格适用于模块安装到 DIN 导轨上以及安装到金属框架的情形。

外形尺寸

图1 OC10-CN LX/OC10-CPLX OC10-IC2NLX/OC10-IC2PLX



图2 OC10-ICNLQ8/OC10-ICPLQ8 OC10-C2NLQ8/OC10-C2PLQ8



操作指示

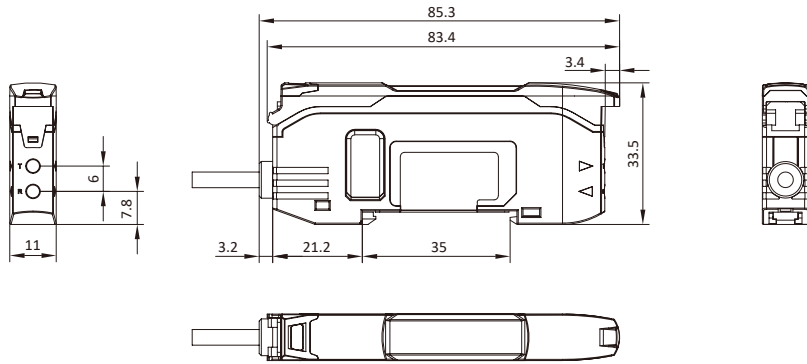
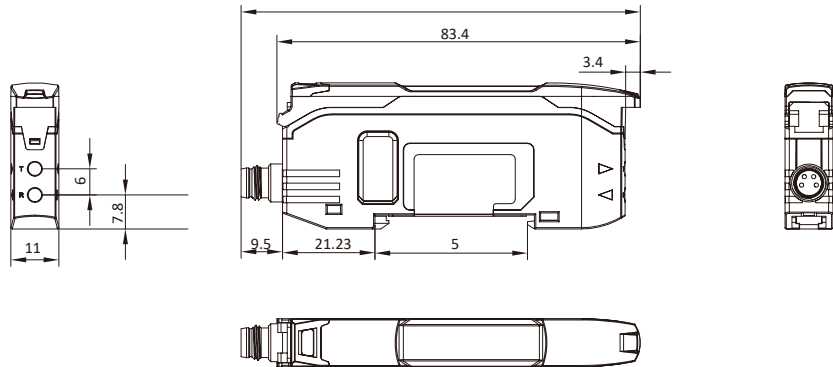
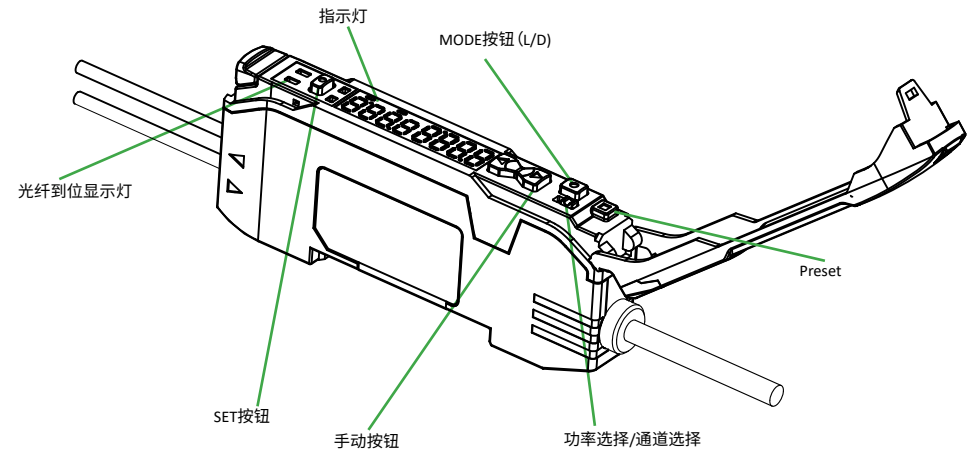

基本操作:

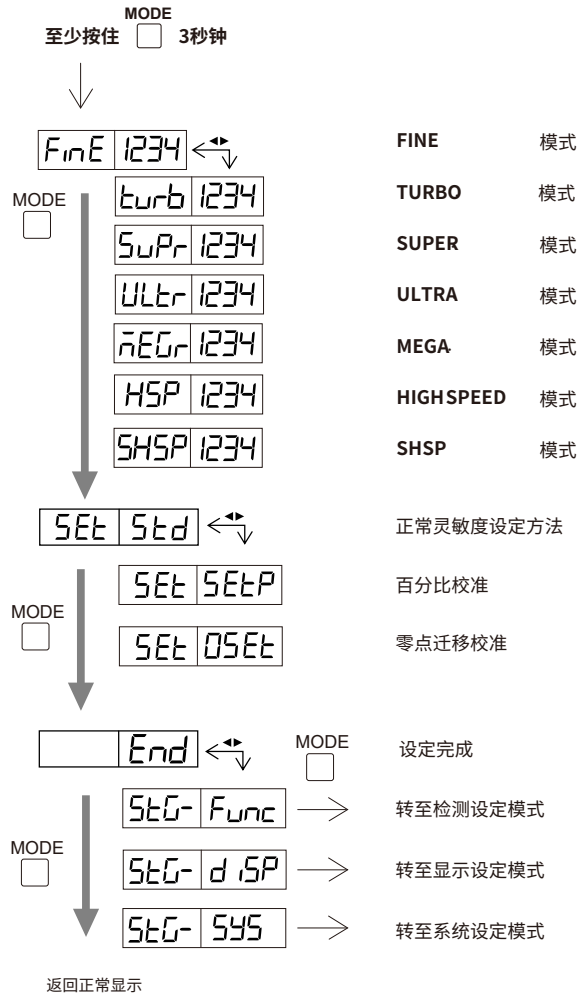

检测设置:

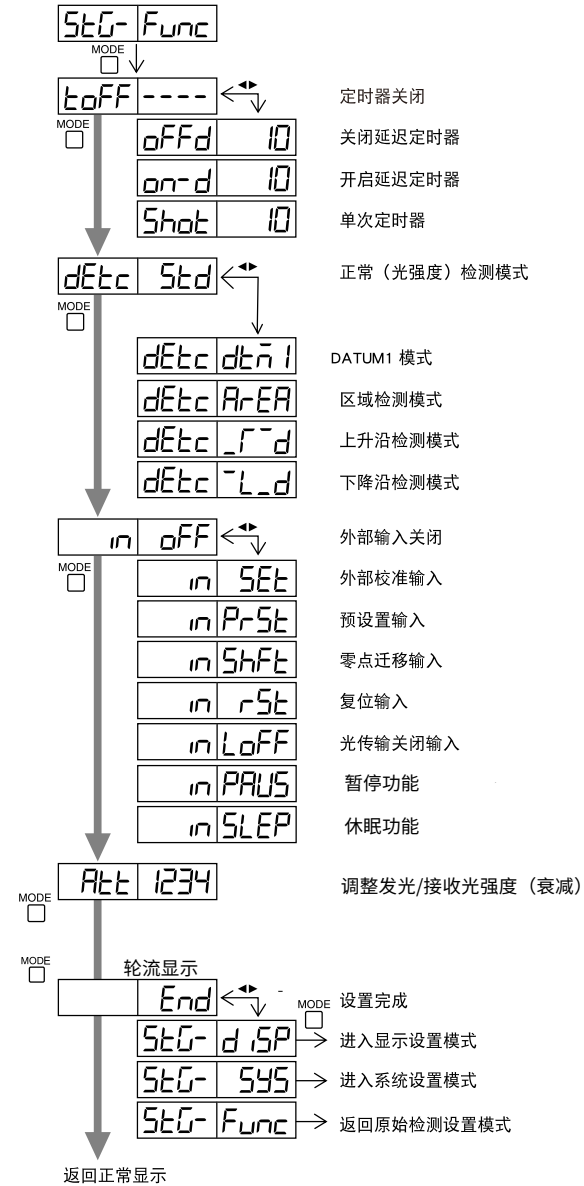

显示设置:

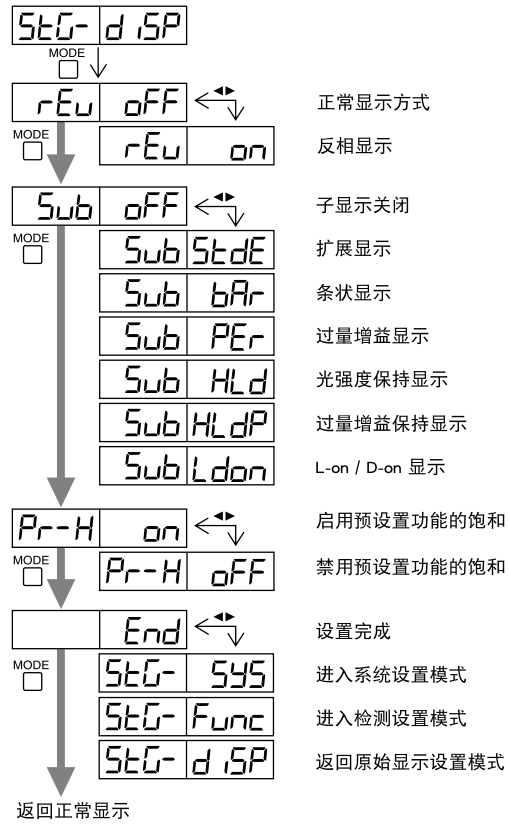

系统设置:

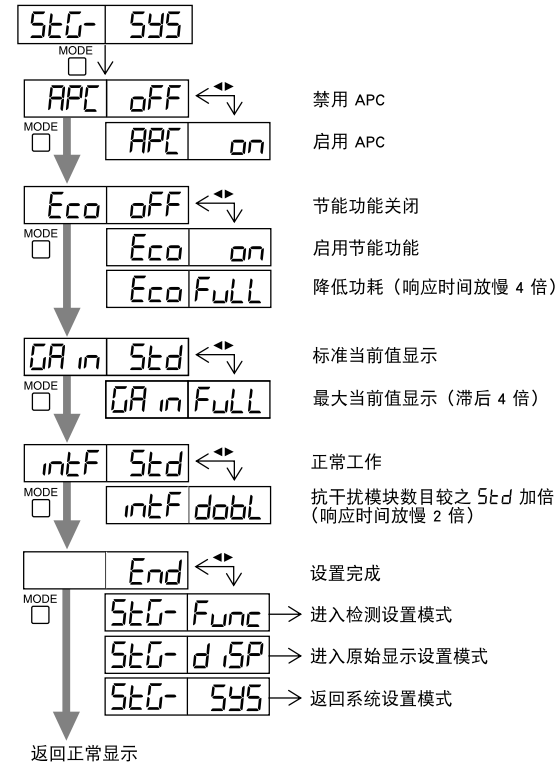

2路输出:

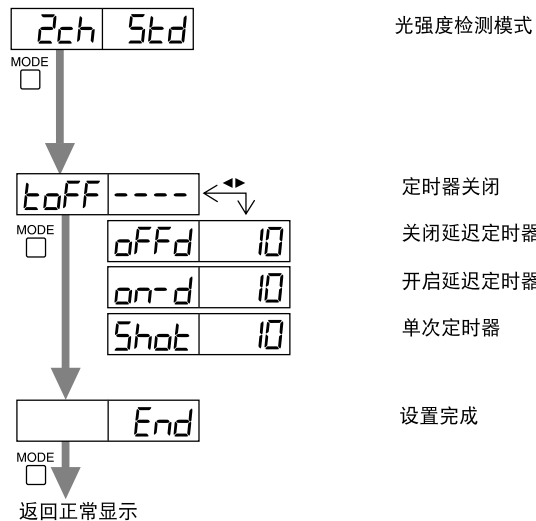

### 饱和取消功能

启用饱和取消功能: 按住 [MODE] 按钮的同时按 [SET] 按钮。  
已针对与功率模式相对应的接收光强度, 在如下表所示的范围内作出设置。

功率模式	接收光强度的设定范围
HSP 、 FINE 、 TURBO	2047±350
SUPER	4095±500
ULTRA 、 MEGA	5000±600

禁用饱和取消功能: 按住 [MODE]按钮的同时按 [SET]按钮。

### 三种定时功能

可用的定时器类型有三种。

显示	功能	定时图表
toFF	不使用定时器功能。(默认设定)	
oFFd	关闭延迟定时器 在检测信号消失以后的指定时间关闭输出。 设置范围: 1 至 9999 ms 默认值: 10 ms	
on-d	开启延迟定时器 在检测信号出现以后的指定时间开启输出。该定时器在 ON 持续时间受到限制时很有用, 因为工件不稳(例如由于振动的关系)。 设置范围: 1 至 9999 ms 默认值: 10 ms	
Shot	单次定时器 在检测信号出现以后开启输出并在指定的时间内保持开启状态。 设置范围: 1 至 9999 ms 默认值: 10 ms	

## 输出2的输出定时器

可用的定时器类型有三种。

显示	功能	定时图表 *
toFF	不使用定时器功能。(默认设定)	<p>没有工件 有工件 没有工件</p> <p>控制输出</p> <p>ON</p> <p>OFF</p>
oFFd	关闭延迟定时器 在检测信号消失以后的指定时间关闭输出。 设置范围: 1 至 9999 ms 默认值: 10 ms	<p>没有工件 有工件 没有工件</p> <p>控制输出</p> <p>ON</p> <p>OFF</p> <p>定时器设定期限</p>
on-d	开启延迟定时器 在检测信号出现以后的指定时间开启输出。该定时器在 ON 持续时间受到限制时很有用, 因为工件不稳(例如由于振动的关系)。 设置范围: 1 至 9999 ms 默认值: 10 ms	<p>没有工件 有工件 没有工件</p> <p>控制输出</p> <p>ON</p> <p>OFF</p> <p>定时器设定期限</p>
Shot	单次定时器 在检测信号出现以后开启输出并在指定的时间内保持开启状态。 设置范围: 1 至 9999 ms 默认值: 10 ms	<p>没有工件 有工件 没有工件</p> <p>控制输出</p> <p>ON</p> <p>OFF</p> <p>定时器设定期限</p>

## 输出切换 (L-on/D-on)

### 此功能配置何时输出为ON

1 显示当前接收到的光强度时, 按[MODE]按钮。显示当前输出条件(L-on或D-on)。

2 按下 按钮以切换输出条件, 然后按[MODE]按钮。对于对照型或回归反射型, 如果要在光束被挡住(工件存在)时输出ON信号, 请选择“D-on”。

对于反射型, 如果要在接收到光束(工件存在)时输出ON信号, 请选择“L-on”。

切换输出条件时, 会显示当前接收到的光强度。

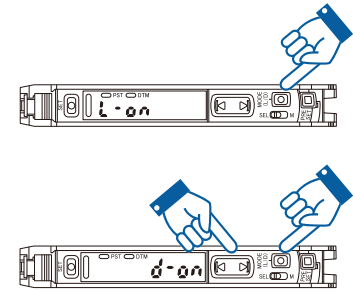

### 1. 预设功能

启用预设功能: 没有工件时, 简单按下[PRESET]按钮, 就可完成灵敏度调整。当按下PRESET 按钮时, 软件记录3秒以内光强最大值, 将光强最大值作为100%基准值。同时设定值设置为50%, PST指示灯亮。

禁用预设功能: PST 指示灯亮起时, 请按住 [PRESET] 按钮。PST 指示灯熄灭时表示工作预设功能已禁用。

### 2. 工作预设功能

此功能会将当前值校正为".0"。在使用参数"100.0"执行预设功能后, 再使用".0"参数 执行此功能, 可将 2 个随机设定点校准为"100.0"与".0"。启用工作预设功能: 启用预设功能时, 同时按下 [PRESET] 按钮和[右]按钮。将该点的接收光强度设为 ".0"。而利用预设功能设为 "100.0", 值不会变化。

禁用工作预设功能: PST 指示灯亮起时, 请按住 [PRESET] 按钮。PST 指示灯熄灭时表示工作预设功能已禁用。

### 3. 最大灵敏度预设定

此功能可将参考状态校准为".0",并将接收光强度状态设置的略高些,即:"100.0"。此功能可与反射型一起使用,用于在以背景作为基准时执行探测工作。

启用最高灵敏度预设定功能:采用反射型设备但没有工件时,或采用对照型/回归反射型设备而有工件时,按住 [PRESET] 按钮三秒以上的时间,同时 PST 指示灯为OFF。当"Auto"灯闪烁时,松开按钮。校准完成,此时 PST 指示灯显示为橙灯且设定值设为"50.0"。

禁用最高灵敏度预设定功能:PST 指示灯亮起时,请按住 [PRESET] 按钮。此时 PST 指示灯会熄灭,表示最高灵敏度预设定功能已禁用。

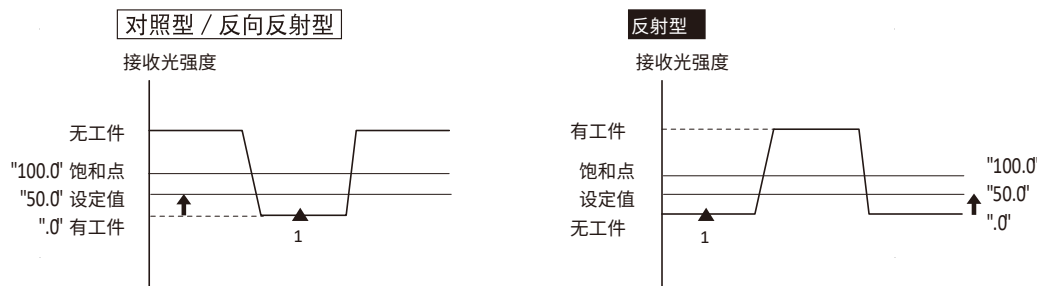

### 4. 两点校准

两点校准是灵敏度设定的最基本方法。只需在工件存在和不存在时分别按 [SET] 按钮一次,即可建立设定值。工件不存在时,按 [SET] 按钮一次。工件存在时,按 [SET] 按钮一次。设定值校准完成,按下[左][右]按钮,调整设定值。

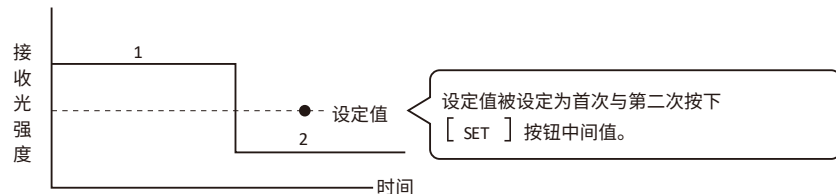

### 5. 最大灵敏度校准

采用反射型设备且没有工件时,或采用“对照型/回归反射型”设备且有工件时,按住 [SET] 按钮三秒以上的时间。当"Set"灯闪烁时,松开按钮。设定值校准完成,按下左右按钮,调整设定值。



### 6. 全自动校准

此方法使用移动工件自动设定灵敏度。在不关闭操作设备的情况下,可以在工件通过时轻松设定灵敏度。当无工件存在时,按住 [SET] 按钮,直到 "Set" 闪烁为止。工件完全通过以后,松开 [SET] 按钮。设定值校准完成

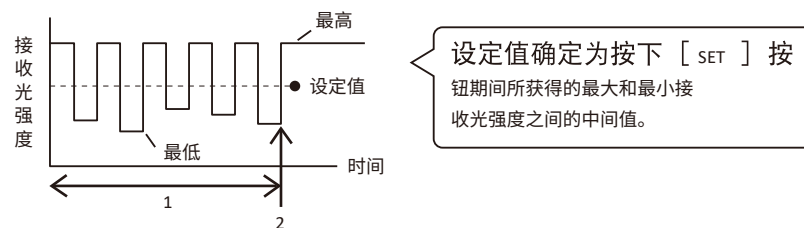

## 7. 定位校准

工件不存在时，按 [SET] 按钮一次。放置工件，使其边缘与投影光束的中心对齐。然后，按住 [SET] 按钮三秒钟以上的时间。当 "Set" 闪烁时，松开按钮。按下 [左] [右] 按钮，调整设定值。工件到达位置时，设定值确定为接收光强度值。

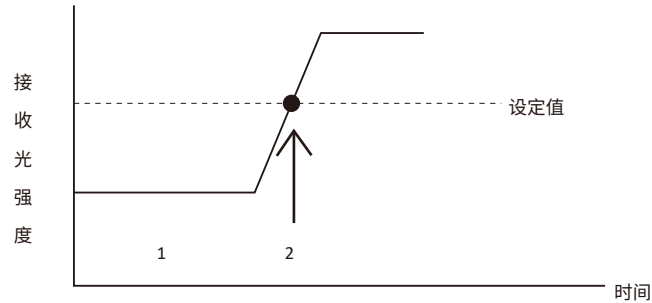

## 8. 零点迁移功能

此功能将当前接收到的光强度的显示调整为 "0"。此功能主要用于反射型传感器。安装反射型设备时，如果接收到的光强度无法设定为 "0"，可以在无工件存在的情况下使用此功能将接收到的光强度设定为 "0"。这样可以更加容易地辨别接收到的光强度的差异。

**启用零点迁移功能：** PST 指示灯熄灭时，请同时按 [PRESET] 按钮与 [右] 按钮。此时 PST 指示灯变橙，并且接收到的光强度会更改为 "0"。

**禁用零点迁移功能：** 按住 [PRESET] 按钮。PST 指示灯熄灭，表示零点迁移功能已禁用。

## 9. 加载推荐设置（菜单功能）

同时按住 [SET] 和 [PRESET] 按钮保持三秒钟或更长时间。"rSt" 显示会闪烁按下左右按钮，显示 "LoAd"，然后按 [MODE] 按钮。按下左右按钮以选择所需的菜单设定，然后按 [MODE] 按钮。加载设置后，画面显示 "LoAd oK" 随后会替换为当前接收到的光强度

## 10. 初始化

传感器放大器可以重设为出厂默认设定。同时按住 [SET] 和 [PRESET] 按钮保持三秒钟或更长时间。"rSt" 显示会闪烁。按 [MODE] 按钮。按下 [左] [右] 按钮以显示 "init"。按 [MODE] 按钮。初始化设置后，画面显示 "oK"，随后会替换为当前接收到的光强度

## 11. 按键锁定

按键锁定功能可以禁止所有按键操作，以防止未经授权的使用。

**激活按键锁定：** 同时按住 [MODE] 按钮和 [左]（或 [右]）保持三秒钟或更长时间。画面显示 "Loc"，同时禁止操作按键并显示当前接收到的光强度。

**停用按键锁定：** 同时按住 [MODE] 按钮和 [左]（或 [右]）保持三秒钟或更长时间。此时画面会显示 "unL"，同时允许按键操作。

## 12. 带 PIN 号码的按键锁定

激活按键锁定时，可以设定 PIN 号码。只有知道 PIN 号码的用户才能操作该模块。

**激活带 PIN 号码的按键锁定：** 按 (左键或右键) 10 次，同时按住 [MODE] 按钮。此时画面会显示 "Loc 0"。按下左右键按钮以设定所需的号码（最多四位数）。按 [MODE] 按钮。画面显示 "Loc"，同时禁止操作按键并显示当前接收到的光强度。

**停用带 PIN 号码的按键锁定：** 按住 [MODE] 按钮，同时按 (左键或右键) 十次。此时画面会显示 "Loc 0"。按下左右键按钮以指定 PIN 号码，然后按 [MODE] 按钮。此时画面会显示 "unL"，同时允许按键操作。

### 13. 功率模式设定

在1通道, 光强显示界面下按住[MODE]按钮三秒钟, 进入功率设置界面。

按下[左][右] 按钮选择不同的功率模式。

显示	功率模式名称	响应时间
ShSP	SUPER HIGH SPEED 模式	23 $\mu$ s
hSP	HIGH SPEED 模式	50 $\mu$ s
FinE	FINE模式 (默认设定)	250 $\mu$ s
turb	TURBO 模式	500 $\mu$ s
SuPr	SUPER 模式	1 ms
ULtr	ULTRA 模式	4 ms
MEGA	MEGA 模式	16 ms

### 14. 灵敏度设定

#### 14.1 百分比校准

可按照与当前接收光强度的比例配置设置值。此值可以在 "1P" (1%) 到 199P (199%) 范围内设定。默认值: 90P (90%)。在所需的参考状态下, 按 [SET]按钮。

设置示例: 假设百分比校正目标值设定为 "90%"

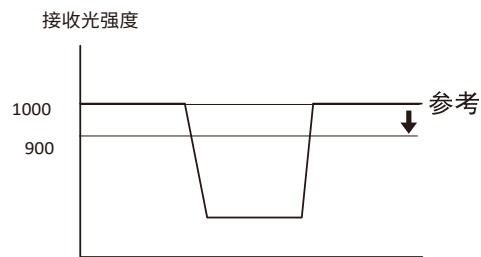

#### 14.2 零点迁移校准

此灵敏度设定将同时执行零点迁移功能和基本校准(两点校准 / 最高灵敏度校准 / 全自动校准)。设定灵敏度时所指定接收光强度值的下限将自动设定为 "0"。

设置示例: 当有工件时接收到的光强度为 "2500", 无工件时接收到的光强度为 "500", 如果使用反射型执行两点校准:

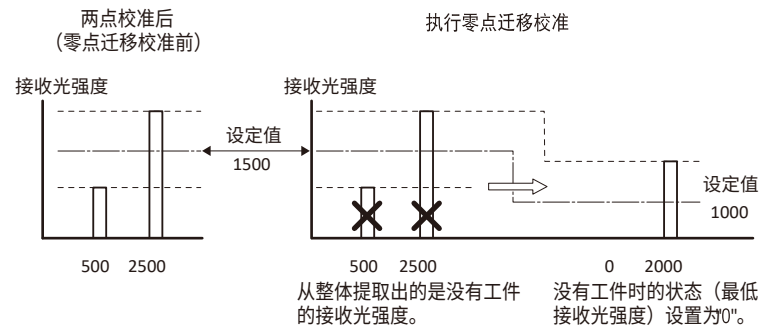

## 15. 检测模式

### 15.1 DATUM1 模式

在 DATUM1 模式下,无工件时接收到的光强度 始终校正为 "100.0"。此外,设定值也会根据校正量进行校正,以便设定值和接收到的光强度之比 保持不变,从而实现稳定检测。设定值的显示不会发生变化。DATUM 模式适用于接收到的光强度逐渐变化的 环境,例如,传感头易受污染或大幅温度变化影响的环境。

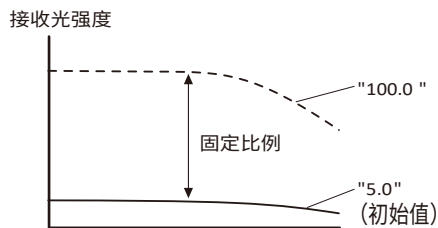

更改警告输出电平:

检测到接收到的光强度的较小变化量并未引起输出开启,模块进入报警模式。如果接收到的光强度持续保持在警告水平和设定水平之间,接收到的光强度校正会停止,DTM 指示灯会闪烁且模块进入报警模式。

**显示示例** 当警告输出电平设定为 50%、dtm1、D-on 时:

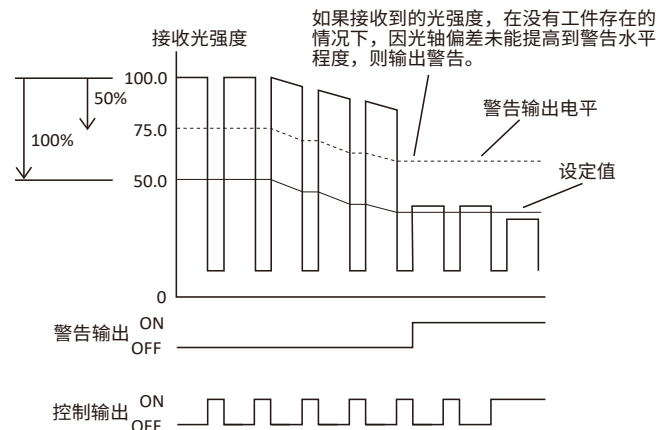

可以在 0P (0%) - 100P (100%) 范围内设定输出警告的水平。(默认值50P (50%))。

- 100P (100%) : 如果接收到的光强度会变化,则模块不会进入报警模式。
- 50P (50%) : 如果没有检测到工件,当接收到的光强度低于接收到的光强度和设定值的中间值时,模块进入报警模式。
- 0P (0%) : 即使接收到的光强度发生微小变化,模块也会进入报警模式。

可以从以下三种水平选择所需的校正间隔:

功率模式	LEv1 (LEVEL1)	LEv2 (LEVEL2)	LEv3 (LEVEL3)
HIGH SPEED	4.4 s	547.2 ms	34.2 ms
FINE	13.1 s	1.64 s	102.4 ms
TURBO/SUPER/ULTRA/MEGA	26.2 s	3.27 s	204.8 ms

### 15.2 区域检测模式

在此模式下,如果接收到的光强度在 Hi (上限) 和 Lo (下限) 限定的范围内,则会传递输出信号

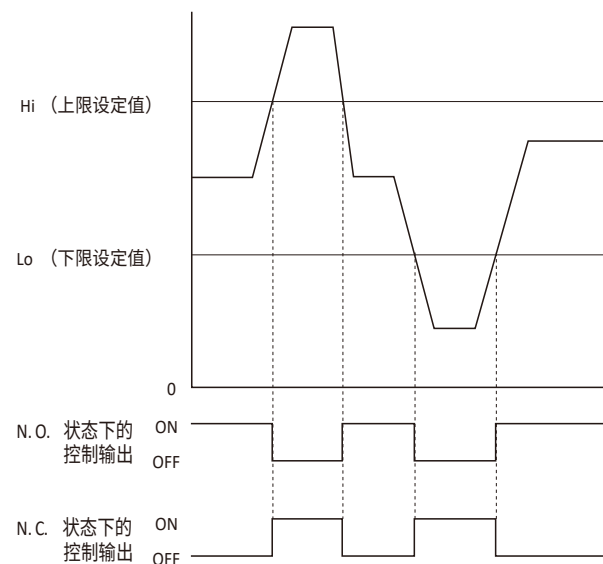

按[左][右]以显示 "Hi" 或 "Lo"。Hi " 或 "Lo" 值和当前设定值会交替显示。如果在显示交替闪烁时按 [MODE]按钮,则 "Hi" 或 "Lo" 显示会发生变化。如果您在三秒钟或更长时间内没有执行任何操作,则接收到的光强度显示会自动恢复。按[左][右]按键调整比较值,确保【hi】值大于【low】值。

### 15.3 边缘检测模式

在边缘检测模式下,传感器放大器会检测接收到的光强度在一段固定时间内的变化。只有在工件正在移入或移出光纤模块检测范围时,此模式才会用来开启输出。接收到的光强度衰减时,输出设定为 ON →选择 "L\_d" (下降沿检测模式)。接收到的光强度上升时,输出设定为 ON →选择 "I\_d" (上升沿检测模式)。

## 16. 外部输入

16.1 Set: 外部校准输入, 使用外部输入来执行校准操作。

16.2 PrSt: 预设输入, 使用外部输入来执行预设操作。

16.3 ShFt: 零点迁移输入, 使用外部输入来执行零点迁移操作。

16.4 rSt: 复位输入, 使用外部输入来执行复位操作。

16.5 LoFF: 传输 OFF 输入, 在信号输入过程中, 使传输保持关闭状态。

16.6 PAUS: 暂停功能, 在外部输入期间锁定输出条件。在信号输入过程中, 无论接收到的光输入如何, 都可以将输出锁定在所需的状态。

16.7 SLEP: 休眠功能, 在外部输入期间使用省电模式。

## 17. 调整发光 / 接收光强度 (Func-Att)

当功能强大 (检测范围更长) 的光纤模块用于较短的范围中时, 则无论工件是否存在, 接收光强度均可能保持为启用的显示范围中的最大值 (饱和)。(示例: 最大值 9999 的数值不变) 在这种情况下, 通过使用衰减功能可手动将发光和接收光强度自动校正至最佳状态。使用左右键按钮减小下限值, 接收光强度会衰减更多。设置范围: 1 至 100 (初始值: 100)。

## 18. 显示反转 (DiSP-rEu)

当前值与设定值会反转显示。

显示	功能
oFF (OFF)	正常显示 (默认设定)
on (ON)	反转后显示

## 19. 扩充显示 (DiSP-Sub-StdE)

通常显示为四位数接收光强度会扩展到五位显示。设定值的上限始终为四位数 (9999)。无法设定更大的值。

## 20. 条形显示 (DiSP-Sub-bAr)

接收到的光强度可以显示为条形图。条形以实时方式显示, 范围为 85% - 115%, 间隔为 5%, 其中 100% 为设定值。最多显示八个条形

## 21. 过量增益 (%) 显示 (DiSP-Sub-PER)

接收到的光强度显示为相对于设定值的过量增益。在屏幕上, 接收到的光强度显示为条形图和百分比数字。过量增益 = (接收到的光强度/设定值) x 100。

## 22. 光强度保持显示 (DiSP-Sub-HLd)

接收到的光强度的最大峰值和最小谷值可以连续显示。可以从五种可能的显示组合中进行选择。

显示	显示的值
Std (Standard)	每当当前接收到的光强度分别低于或高于设定值时, 更新峰值或谷值。(默认设定)
P~P_ (Peak Max/Peak Min)	显示自电源开启以来峰值的最大值和最小值。(累积)
b~b_ (Bottom Max/Bottom Min)	显示自电源开启以来谷值的最大值和最小值。(累积)
P_b~ (Peak Min/Bottom Max)	显示自电源开启以来峰值的最小值和谷值的最大值。(累积)
P~b_ (Peak Max/Bottom Min)	显示自电源开启以来峰值的最大值和谷值的最小值。(累积)

## 23. 过量增益保持 (%) 显示 (DiSP-Sub-HLdP)

此功能与“接收到的光强度保持显示”相同, 只不过正在保存的值显示为过量增益, 而不是接收到的光强度。

## 24. 预设饱和功能 (DiSP-Pr-H)

当预设饱和功能设定为ON时,可以在 100P (100%) 至200P (200%) 范围内设定饱和水平。例如,如果此功能设定为 150P,则在启用预设饱和功能时,接收到的光强度将校正为 "150.0",并且数字显示将显示"100.0"。高级功能设置饱和水平可以设定为较高的值,以便即使在易受污染(例如灰尘)影响的环境中也能实现稳定的检测。如果要在使用预设饱和功能或 DATUM1 模式的应用中显示高于"100.0"的值,请关闭此功能。

显示	功能
on (ON)	当实际接收到的光强度高于 100.0 时,将显示固定为 "100.0 " (不显示高于 "100.0 " (默认值: 110P )
oFF (OFF)	按原样显示实际接收到的光强度,即使高于 "100.0 " 也是如此。

预设输入用于将光强度记录为 "100.0 "。  
 实际接收光强度( 3300 )设定为 "110%",  
 以便所有超过 "100%" 的光强度值都显示为  
 100.0 "。  
 当光强度低于 "100%" 时,会显示一个低于  
 100.0 " 的值。  
 (记录时的百分比值 "110%"(即,饱和水平)可以为 100 和 200% 之间的任何值。)

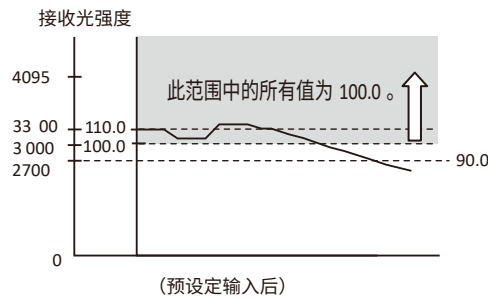

## 25. APC 功能 (SYS-APC)

APC (自动功率控制) 功能以恒定量自动调整发光。该功能可减少由于环境温度变化所引起接收光强度的变化

屏幕显示	功能
oFF (OFF)	APC 功能已禁用 (初始设定)
on (ON)	已启用 APC 功能

## 26. 经济功能 (SYS-Eco)

关闭数字显示和输出指示灯可以降低功耗。

26.1 on(ON): 启用经济功能。(数字显示屏上的一段内容闪烁。)

26.2 FuLL (FULL): 降低功耗(经济功能开启,响应时间增加四倍)

## 27. 显示增益 (SYS-GRin)

在不牺牲响应时间的情况下,可以将接收到的光强度提高四倍。

显示	功能
Std ( Standard )	正常光强度显示 (默认设定)
FuLL ( Full )	全光强度显示 (滞后四倍) 的值)。

## 28. 自定义保存 (设定保存)

1. 同时按住 [SET] 和 [PRESET] 按钮保持三秒钟或更长时间。"rSt" 显示会闪烁。
2. 按下左右键按钮, 显示 "SAvE", 然后按 [MODE] 按钮。
3. 按下左右键按钮, 显示 "YES", 然后按 [MODE] 按钮。保存设置后, 屏幕显示 "oK", 随后会替换为当前接收到的光强度。

## 29. 用户复位 (设定重新调用)

可以重新调用使用自定义保存功能保存的设定。如果执行用户复位, 则使用自定义保存功能保存的设定将覆盖以前的所有设定。

1. 同时按住 [SET] 和 [PRESET] 按钮保持三秒钟或更长时间。"rSt" 显示会闪烁。
2. 按 [MODE] 按钮。
3. 按下左右键按钮, 显示 "USEr", 然后按 [MODE] 按钮。用户复位执行以后, 屏幕会显示 "oK", 随后会替换为当前接收到的光强度。

## 安装模式

将光纤放大器安装到DIN导轨上的安装方法

1. 将产品底部的卡爪与DIN轨道对齐。按照箭头1的方向推动产品的同时, 使其往箭头2的方向倾斜。

将光纤放大器在DIN导轨上的拆卸方法

2. 拆卸传感器的方法是, 在朝箭头1的方向推动产品的同时, 朝箭头3的方向提升产品。

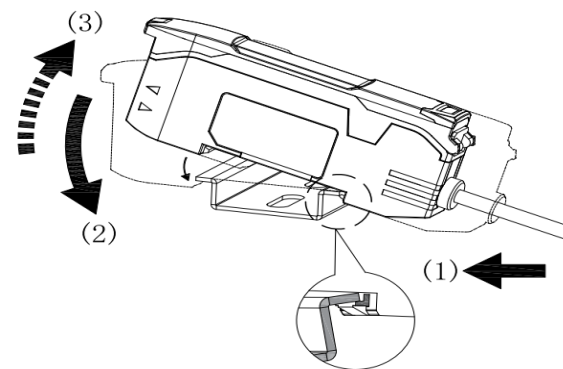

## 安装到墙壁上

将放大器与选配的EOC10-1安装在一起, 并使用螺钉固定住, 如插图所示。

